







Section II – Installation Procedure

A. Installation Precautions

-  1. Use Seat & Floor Protectors to avoid damage to surfaces. (Fig. A1)
-  2. Wear protective latex gloves while cleaning factory panels.

**NOTE:** The use of protective latex gloves during cleaning is mentioned as a precaution to those installers who may be sensitive to the chemicals being used in this process. The use of protective gloves is not mandatory.

-  3. When cleaning with 3M™ Prep-Solvent 70

-  A. Always use a clean (lint free, scratch resistant) soft cloth (or wipe), and clean a small area at a time (~3 ft. x 3ft. max). (Fig A2)
- B. Shake well.
-  C. Apply 3M™ Prep Solvent-70 solution to cloth or wipe and thoroughly clean surfaces. Do not spray cleaning solutions directly to any vehicle surfaces. (Fig. A3).
-  D. Follow up with clean surface thoroughly with clean distilled water and wipe dry immediately with a new clean cloth. (Fig. A4).

-  4. Dash Appliqué must be between 70°F and 110°F (just prior to actual installation).

-  5. Vehicle dash surfaces must be between 70°F and 110°F (just prior to actual installation).

- 6. Use pull-tabs to remove 3M liners. (Fig. A5).

-  A. Do not touch or allow debris or contaminants to come into contact with the adhesive backing before installation.

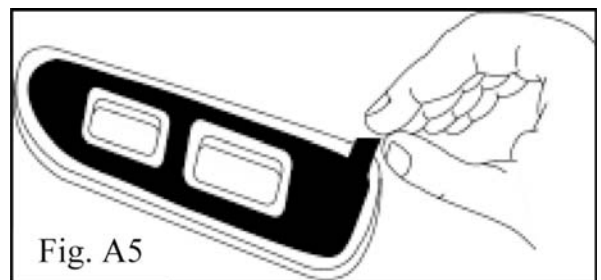
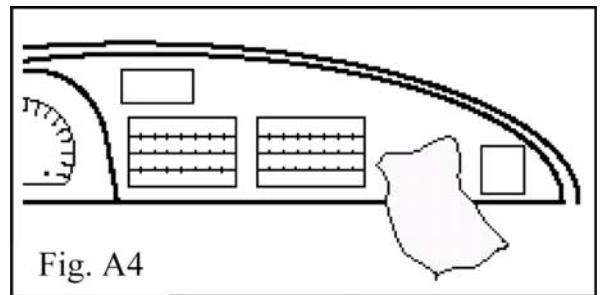
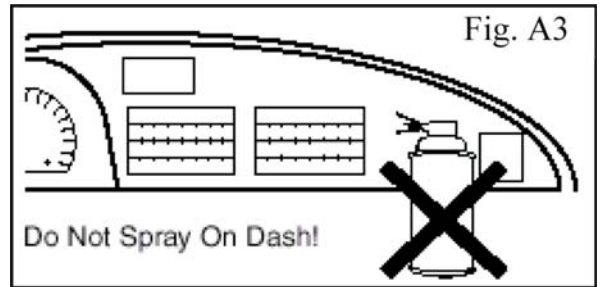
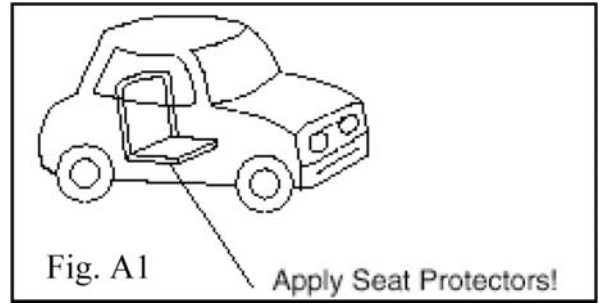

**B. Inspection of Parts**

1. Inspect parts prior to installation to avoid unnecessary removal. (Fig. B1).

**C. Dry Fit Parts**

- 
1. Check placement for alignment of each part.

**D. Clean Factory Surfaces**

1. Thoroughly clean (using method in Step A.3) all applicable surfaces.

**Service Part Numbers: Fig. B1**

Fig. B1

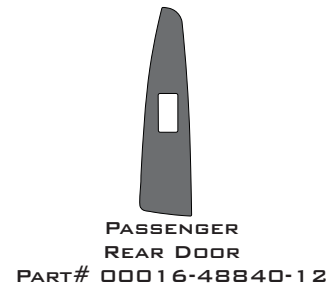
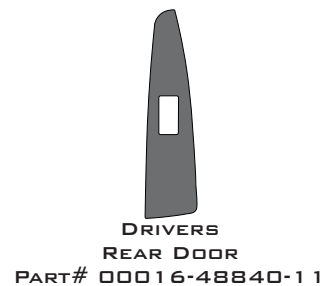
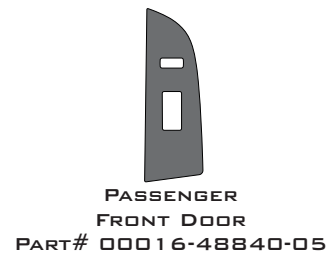
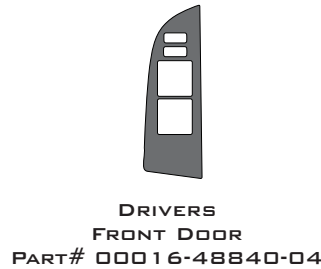
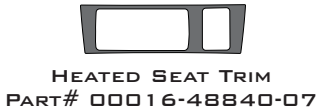
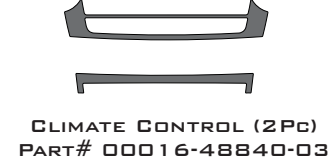
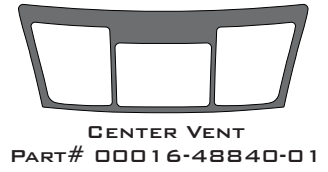

### E. Install Center Vent Trim

 A. Align part uniformly to edge of factory components. Edge of appliqué should be flush to edge of factory component,  $\pm 1.0\text{mm}$ . (Fig. C1).

B. Gently touch part into position.

 2. Remove adhesive liners from part. Be sure not to touch adhesive backing prior to installation.

3. Position and secure part.

 4. Verify alignment.

 5. Press from the center outward to allow the part to lay freely. Roll fingertips in a back and forth motion to set adhesive. Be sure to roll thumb along outside and inside edges while applying pressure.

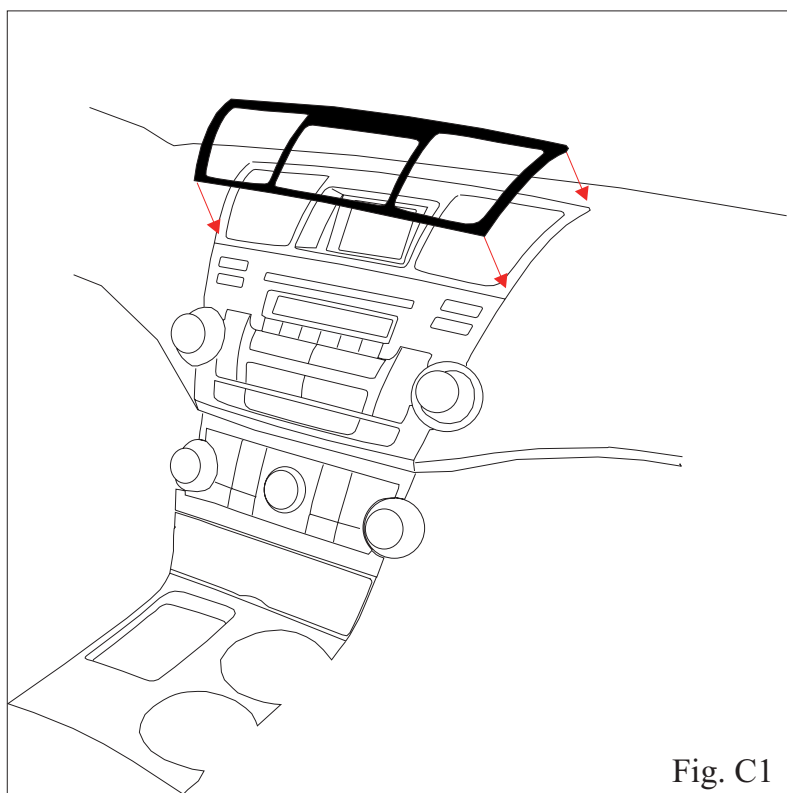



Fig. C1

### F. Audio Trim (2 piece's)

 1. Follow steps to warm components as required.

2. Remove adhesive liners from part. Be sure not to touch adhesive backing prior to installation.

3. Position and secure part.

 A. Align part uniformly to edge of factory components. Edge of appliqué should be flush to edge of factory component,  $\pm 1.0\text{mm}$ . (Fig. C2).

B. Gently touch part into position.

 4. Verify alignment.

 5. Press firmly into place. Roll fingertips in a back and forth motion to set adhesive. Be sure to roll thumb along outside and inside edges while applying pressure.

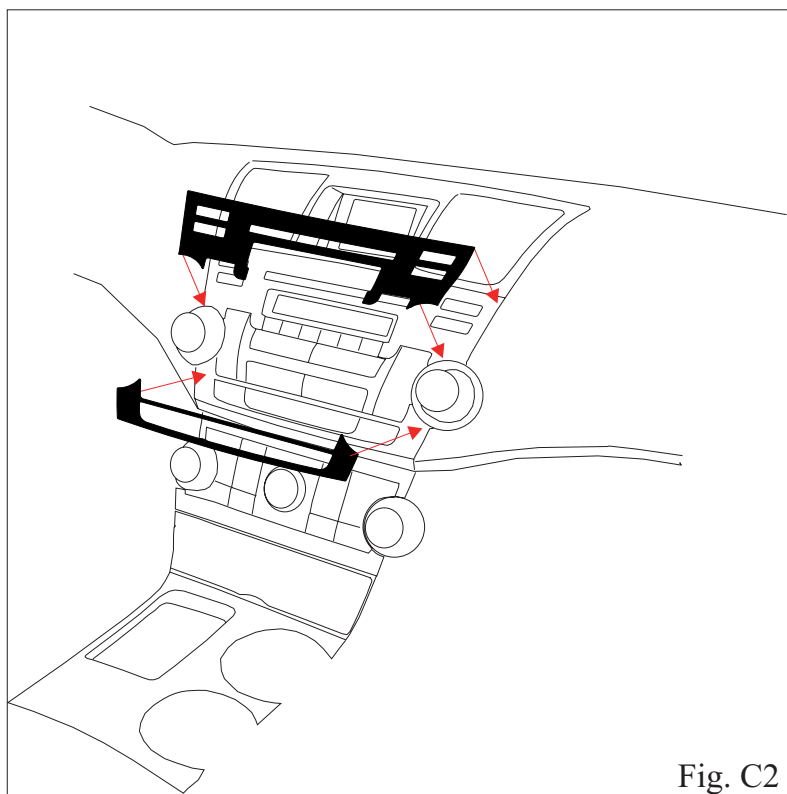



Fig. C2

**E. Climate Control Trim (2 piece's)**

 A. Align part uniformly to edge of factory components. Edge of appliqué should be flush to edge of factory component,  $\pm 1.0\text{mm}$ . (Fig. D1).

B. Gently touch part into position.

 2. Remove adhesive liners from part. Be sure not to touch adhesive backing prior to installation.

3. Position and secure part.

 4. Verify alignment.

 5. Press firmly into place. Roll fingertips in a back and forth motion to set adhesive. Be sure to roll thumb along outside and inside edges while applying pressure.

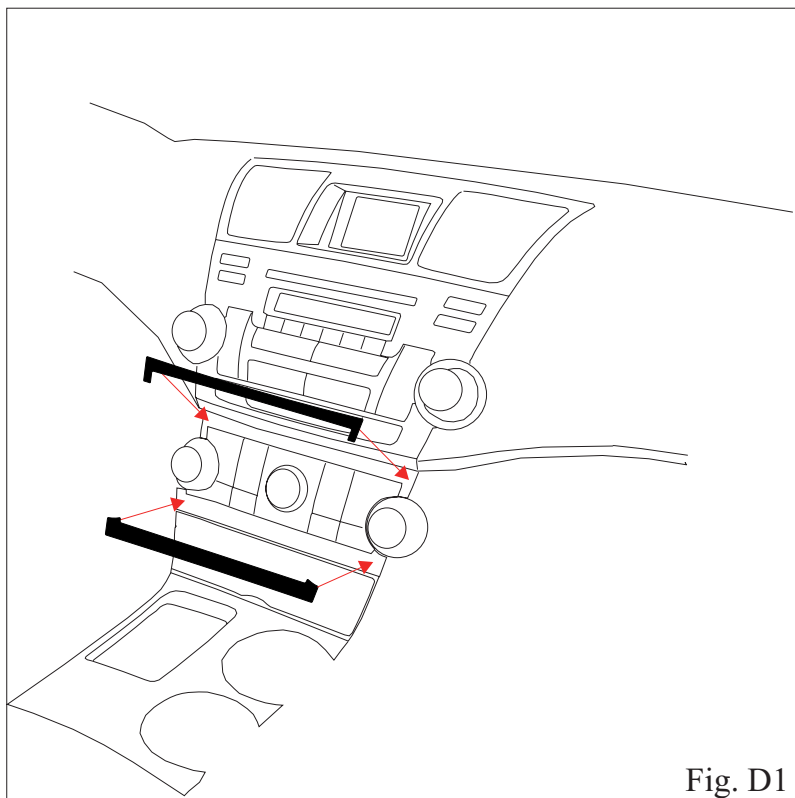



Fig. D1

**F. Storage Door or Heated Seat Trim**

 1. Follow steps to warm components as required.

2. Remove adhesive liners from part. Be sure not to touch adhesive backing prior to installation.

3. Position and secure part.

 A. Align part uniformly to edge of factory components. Edge of appliqué should be flush to edge of factory component,  $\pm 1.0\text{mm}$ . (Fig. D2).

B. Gently touch part into position.

 4. Verify alignment.

 5. Press firmly into place. Roll fingertips in a back and forth motion to set adhesive. Be sure to roll thumb along outside and inside edges while applying pressure.

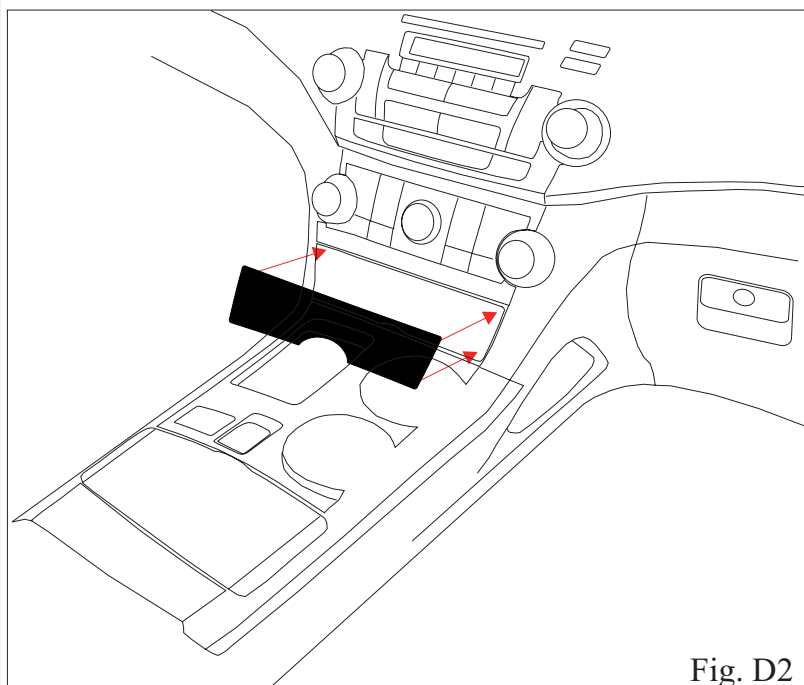





Fig. D2

**E. Center Console Trim**

-  A. Align part uniformly to edge of factory components. Edge of appliqué should be flush to edge of factory component,  $\pm 1.0\text{mm}$ . (Fig. E1).
- B. Gently touch part into position.
-  2. Remove adhesive liners from part. Be sure not to touch adhesive backing prior to installation.
- 3. Position and secure part.
-  4. Verify alignment.
-  5. Press firmly into place. Roll fingertips in a back and forth motion to set adhesive. Be sure to roll thumb along outside and inside edges while applying pressure.

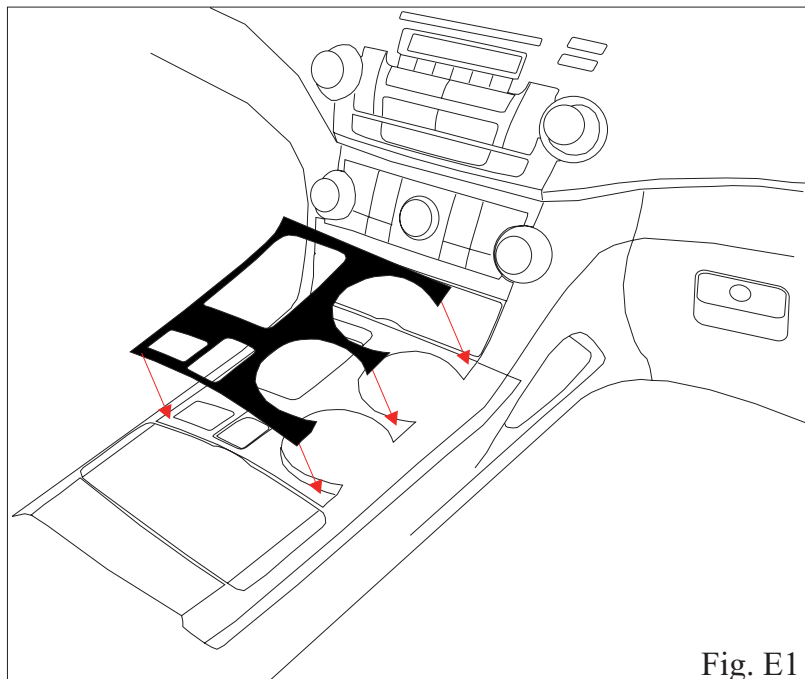





Fig. E1

**F. Cup Holder Trim**

-  1. Follow steps to warm components as required.
- 2. Remove adhesive liners from part. Be sure not to touch adhesive backing prior to installation.
- 3. Position and secure part.
-  A. Align part uniformly to edge of factory components. Edge of appliqué should be flush to edge of factory component,  $\pm 1.0\text{mm}$ . (Fig. E2).
- B. Gently touch part into position.
-  4. Verify alignment.
-  5. Press firmly into place. Roll fingertips in a back and forth motion to set adhesive. Be sure to roll thumb along outside and inside edges while applying pressure.

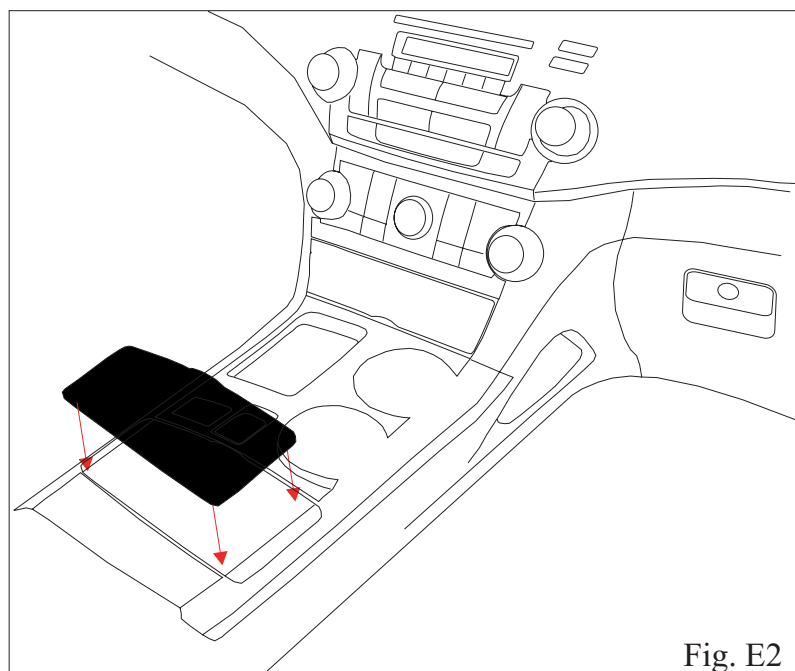



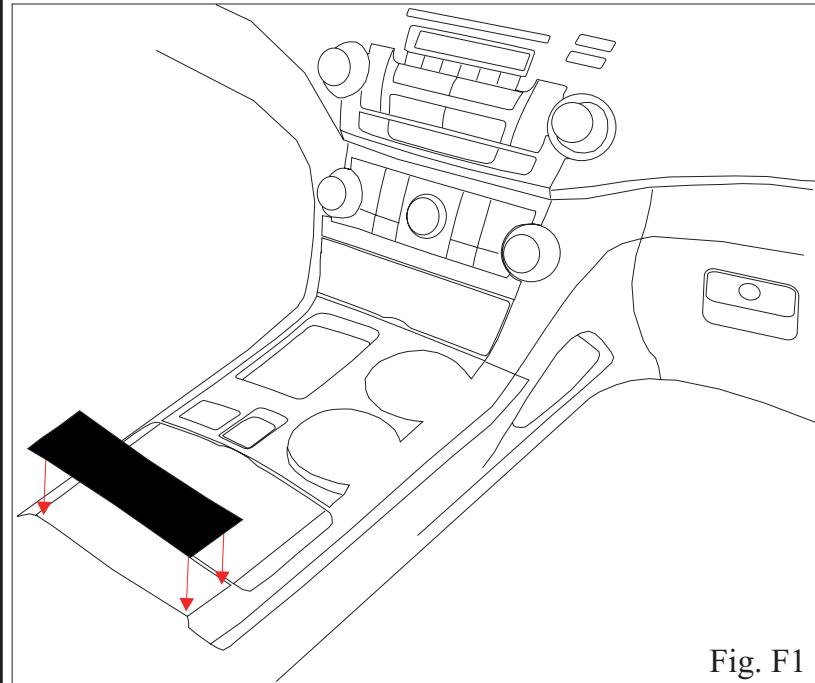





Fig. E2

**E. Lower Console Trim**

-  A. Align part uniformly to edge of factory components. Edge of appliqué should be flush to edge of factory component,  $\pm 1.0\text{mm}$ . (Fig. F1).
- B. Gently touch part into position.
-  2. Remove adhesive liners from part. Be sure not to touch adhesive backing prior to installation.
- 3. Position and secure part.
-  4. Verify alignment.
-  5. Press firmly into place. Roll fingertips in a back and forth motion to set adhesive. Be sure to roll thumb along outside and inside edges while applying pressure.



**F. Driver and Passenger Front & Rear Doors**

-  1. Follow steps to warm components as required.
- 2. Remove adhesive liners from part. Be sure not to touch adhesive backing prior to installation.
- 3. Position and secure part.
-  A. Align part uniformly to edge of factory components. Edge of appliqué should be flush to edge of factory component,  $\pm 1.0\text{mm}$ . (Fig. F2).
- B. Gently touch part into position.
-  4. Verify alignment.
-  5. Press firmly into place. Roll fingertips in a back and forth motion to set adhesive. Be sure to roll thumb along outside and inside edges while applying pressure.

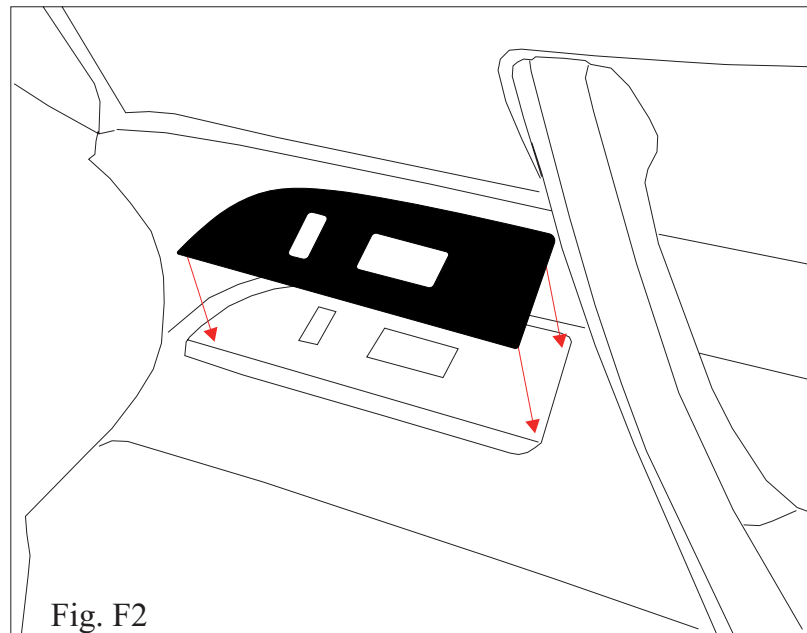



Section III – Functional Verification

Check:

---

Main IP Switches and Buttons

Storage Door

Look For:

---

All buttons and switches should function properly,  
no sticking.

Storage Door should function properly, open and close,  
no sticking.