



Care must be taken when installing this accessory to ensure damage does not occur to the vehicle. The installation of this accessory should follow approved guidelines to ensure a quality installation.

These guidelines can be found in the "Accessory Installation Practices" document.

This document covers such items as:-

- Vehicle Protection (use of covers and blankets, cleaning chemicals, etc.).
- Safety (eye protection, rechecking torque procedure, etc.).
- Vehicle Disassembly/Reassembly (panel removal, part storage, etc.).
- Electrical Component Disassembly/Reassembly (battery disconnection, connector removal, etc.).

Please see your Toyota dealer for a copy of this document.

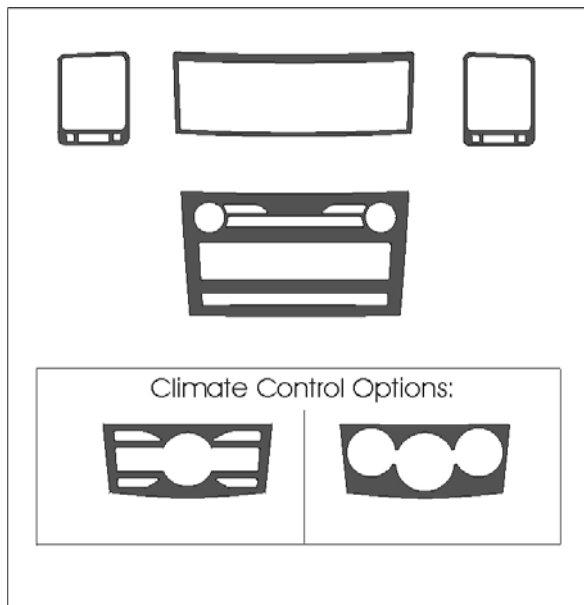

Fig. 1-1

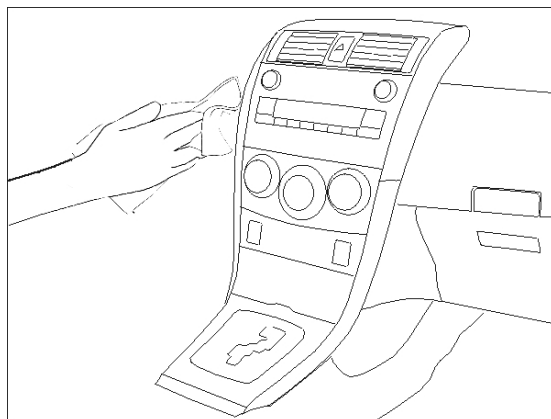



Fig. 2-1

### 1. Check Kit Content.

- (a) Check kit for content and damage. (Fig. 1-1)

### 2. Installation Preparation.

- (a) Thoroughly clean all installation surfaces.
  - (i) Use a clean lint free cloth.
  - (ii) Clean surface thoroughly using VDC approved cleaner and wipe dry. Do not allow cleaner to air dry. (Fig. 2-1)
- (b) Ensure appliqué is between 70 F and 110 F at time of installation.
-  (c) Ensure vehicle surfaces to be between 70 F and 110 F at time of installation.
- (d) Do not touch or allow debris or contaminants to come in contact with the adhesive backing before installation.

Inspect parts prior to installation. Dry fit.

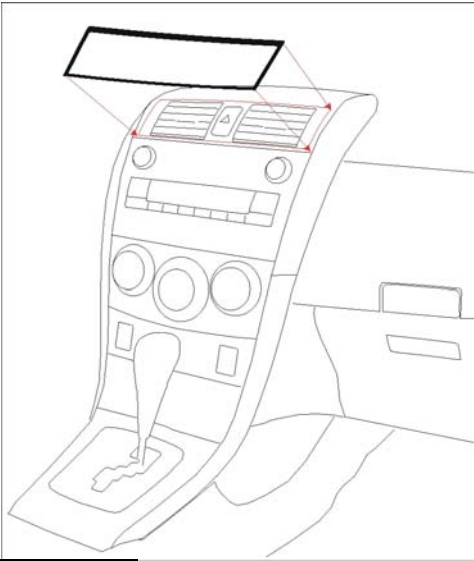

Fig. 3-1

### 3. Install Upper Vent Trim.

- (a) Remove the tape liner from the appliqué. Do not touch the adhesive.
- (b) Align part uniformly to the factory core part of the area in be installed. (Fig. 3-1)
- (c) Gently touch the part into position and re-position as necessary. Once positioned correctly apply hand pressure to ensure maximum adhesion contact.

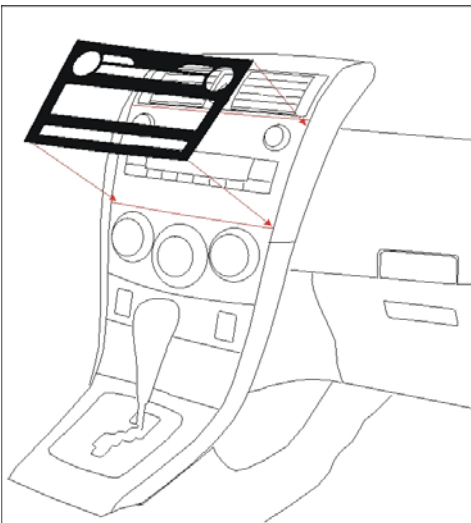

Fig. 4-1

### 4. Install Radio Trim

- (a) Remove the tape liner from the appliqué. Do not touch the adhesive.
- (b) Align part uniformly to the Radio edge and audio button. (Fig. 4-1)
- (c) Gently touch the part into position and re-position as necessary. Once positioned correctly apply hand pressure to ensure maximum adhesion contact.

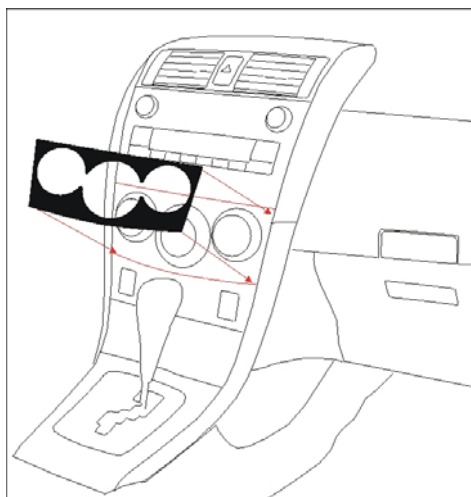
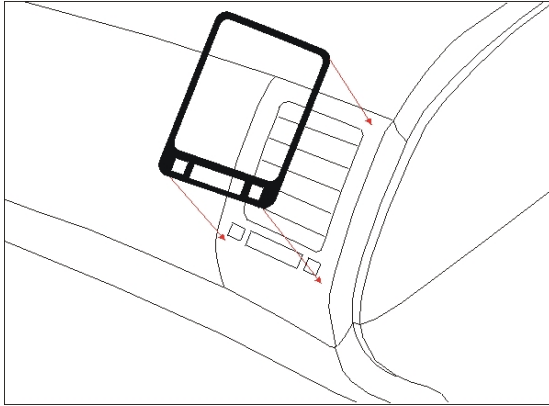

Fig. 5-1

### 5. Install Climate Trim (Digital or Analog)

- (a) Remove the tape liner from the appliqué. Do not touch the adhesive.
- (b) Align part uniformly to the Climate Control edges and dial controls. (Fig. 5-1)
- (c) Gently touch the part into position and re-position as necessary. Once positioned correctly apply hand pressure to ensure maximum adhesion contact.
- (d) maximum adhesion contact.
- (e) maximum adhesion contact.



## **6. Install Passenger Vent Trim**

- (a) Remove the tape liner from the appliqué. Do not touch the adhesive.
- (b) Align part uniformly to the outer edge of the factory vents. (Fig. 9-1)
- (c) Gently touch the part into position and reposition as necessary. Once positioned correctly apply hand pressure to ensure maximum adhesion contact.
- (d) Repeat process for Drivers Vent Trim.

Checklist - these points **MUST** be checked to ensure a quality installation.

Check:

Look For:

Accessory Function Checks

- Dash Appliqué – Adhesive
  
- Dash Appliqué – Alignment
  
- Dash Appliqué - Tolerances

Parts should be securely attached to the vehicle.

Part should be flush to the factory core parts surface.

Confirm tolerances of part to vehicle and make sure all buttons are functional.

Vehicle Function Checks

- Switch Operation.

All switches and storage doors should open and close without any interference from the dash appliqué.